



ELSEVIER

Materials Science and Engineering A297 (2001) 230–234

**MATERIALS
SCIENCE &
ENGINEERING**
A

www.elsevier.com/locate/msea

On the ductile machining of silicon for micro electro-mechanical systems (MEMS), opto-electronic and optical applications

J. Yan¹, M. Yoshino², T. Kuriagawa¹, T. Shirakashi³, K. Syoji, R. Komanduri*

School of Mechanical & Aerospace Engineering, Oklahoma State University, 218 Engineering North, Stillwater, OK 74078-5016, USA

Received 30 March 2000; received in revised form 16 May 2000

Abstract

The role of hydrostatic pressure in the ductile machining of silicon is demonstrated experimentally using a single crystal diamond tool with a large negative rake (-40°) and a high side cutting edge angle (SCEA) ($\sim 88^\circ$) and undeformed chip thickness in the nanometric range (~ 50 nm) using an ultraprecision machine tool and a special machining stage inside a high external hydrostatic pressure (~ 400 MPa) apparatus. © 2001 Elsevier Science B.V. All rights reserved.

Keywords: Silicon; Ductile machining; Ultra-precision machining; Hydrostatic pressure

1. Introduction

Silicon is a nominally brittle material but can be deformed plastically in machining, yielding ductile chips under the influence of high hydrostatic pressure. This involves the use of an extremely rigid, ultraprecision machine tool, a single-crystal diamond tool with a high negative rake angle (-40°) and a high side cutting edge angle ($\sim 88^\circ$) that enables extremely small undeformed chip thickness values (~ 50 nm) at light loads.

Single crystal silicon is not only a dominant substrate material for the fabrication of micro electro and micro mechanical components but also an important infrared optical material [1,2]. Currently, silicon is finished by grinding, lapping and polishing. An alternate approach would be to machine it with a single point tool in the ductile deformation mode without the need for subsequent polishing. This way damage due to brittle fracture can be minimized and reliability of parts in service

can be improved. Silicon is an excellent material for these applications for it can be made extremely pure and practically dislocation-free. It also has an important processing advantage for microelectronic applications in that its oxide, SiO_2 is a good insulator and can be used for isolation and passivation purposes.

Silicon has a strong directional covalent bonding with a diamond structure (4-fold coordination). The predominant slip system is $\langle 110 \rangle \{111\}$. Pure edge dislocations generally do not form in this material; instead pure screw dislocations form with a Burgers vector at 60° to the dislocation line. At room temperature, the dislocations are relatively immobile in silicon and hence, silicon responds in a brittle manner. However, ductility can be imparted at higher temperatures and/or high hydrostatic pressures. In this paper, this will be demonstrated with two examples — one, in ultraprecision machining with a single crystal diamond tool and the other in machining/scratching under high external hydrostatic pressure.

It is known from the theory of plasticity that while the yield strength of the material is determined by the deviatoric stress state, the magnitude of the hydrostatic stress determines the extent of plastic deformation prior to fracture [3]. In other words, hydrostatic pressure determines the strain at fracture that in turn determines the ductility or brittleness of the material under the state of stress. Bridgman [4,5] conducted extensive high

* Corresponding author. Tel.: +1-405-7445900; fax: +1-405-7447873.

E-mail address: ranga@ceat.okstate.edu (R. Komanduri).

¹ Mechatronics & Precision Engineering, Tohoku University, Sendai, Japan.

² Mechanical and Aerospace Engineering, Tokyo Institute of Technology, Tokyo, Japan.

³ Precision Machinery Engineering, Tokyo Denki University, Tokyo Japan.

pressure studies on numerous ‘nominally’ brittle materials, such as stone, chalk and glass and showed that many are capable of ductile behavior (undergoes large strain before fracture) but only under the influence of high hydrostatic pressures. Thus a high value of hydrostatic pressure is a prerequisite for plastic flow to occur in brittle materials at room temperatures. Such conditions fortuitously occur at light loads under an indenter in indentation testing where a spherical symmetry of the bottom half of a spherical cavity is maintained in the deformation zone [Fig. 1 (A)] [6]. Immediately below the indenter, the material is considered as a radially expanding core, exerting a uniform hydrostatic pressure on its surroundings. Encasing the core in an ideally ‘plastic region’ within which flow occurs according to some yield criterion; beyond the plastic region lies the elastic matrix.

It has been reported that crack-free hardness indentation is possible on single crystal silicon at extremely

light loads (~ 0.05 N) [7]. Gerk and Tabor [8] attributed this in part to a structural transformation from diamond cubic (Si-I) into a metallic state β -Sn (Si-II) that could occur under the indenter due to high hydrostatic pressure (10–13 GPa) [9]. They proposed that material around the indenter would become sufficiently ductile (due to in situ metallic transformation) to sustain plastic flow. For example, under high hydrostatic pressure (~ 115 – 120 Kbars) the crystal structure of germanium is found to transform to a six-fold coordination and become metallic. Careful measurements of electrical conductivity during indentation close to the indenter on silicon showed a significant increase in conductivity (from semiconducting to highly conducting) [10,11] strongly supporting a change to metallic state underneath the indenter in which case the material can be deformed plastically or in a ductile mode. It has also been shown from SEM micrographs of the indents in (111) silicon that a thin layer of material immediately adjacent to the indenter is plastically extruded indicating metallic-like mechanical properties [12].

Such conditions of high hydrostatic pressure can be generated immediately underneath the tool at extremely light loads and small size of cut in machining silicon with a high negative rake tool which resembles a blunt indenter [Fig. 1 (B)]. However, to accomplish this requires the use of an extremely rigid, ultraprecision machine tool and a single crystal diamond tool with a high negative rake angle (-40°). In order to obtain extremely small undeformed chip thickness values (~ 50 nm) a straight cutting edge with a large side cutting edge angle (SCEA) ($\sim 88^\circ$) (instead of a tool with a round nose) is required. This will enable thinning of the chip in the nanometric range at the same time provides significant width to undeformed chip thickness ratio to ensure plane strain conditions. Also, the use of plain cutting edge (instead of a nose radius tool) provides a constant value of undeformed chip thickness instead of varying from zero to final value and consequent adverse effect on the stress-state at the tool tip that can result in brittle fracture.

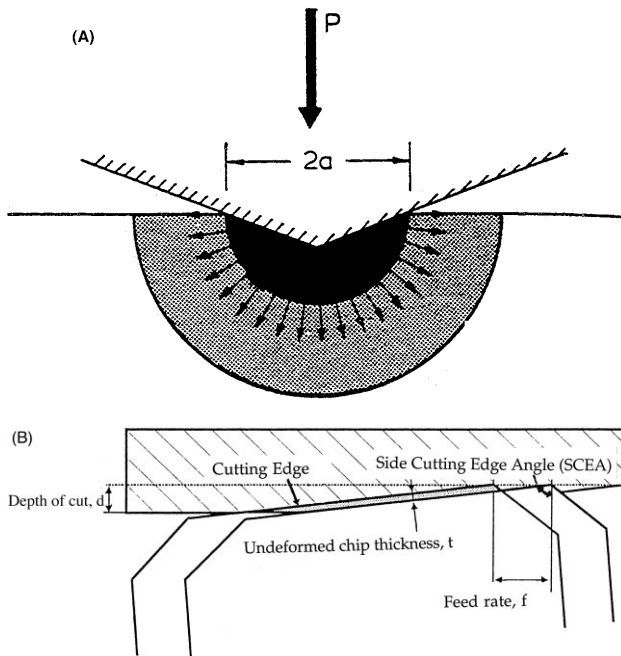

Fig. 1. (A) Model of elastic–plastic indentation. Dark region denoting ‘hydrostatic core’, the shaded region ‘plastic zone’ and the surrounding region ‘elastic matrix’ [6]. (B) Schematic of machining using a straight edge tool with a high side cutting edge angle (SCEA).

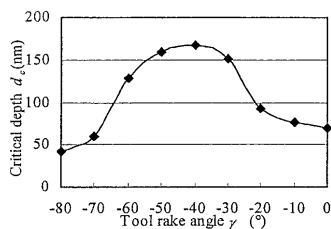

Fig. 2. Variation of the ‘critical’ undeformed chip thickness (or ‘critical’ depth) with the tool rake angle [14].

2. Experimental setups and test conditions

In this investigation, a single crystal silicon with (111) orientation was machined (facing tests) dry using a Toyoda ultraprecision diamond turning machine equipped with a hydrostatic spindle [13]. A single crystal diamond tool with a straight cutting edge (1.2 mm long), a 6° relief angle and rake angles varying from 0 to -80° were investigated. The edge radius was estimated to be ~ 50 nm. The depth of cut was maintained constant at $1 \mu\text{m}$ and the feed rate was varied up to $42 \mu\text{m rev}^{-1}$. This provides an undeformed chip thickness from a few nanometres to $1 \mu\text{m}$. The cutting speed was

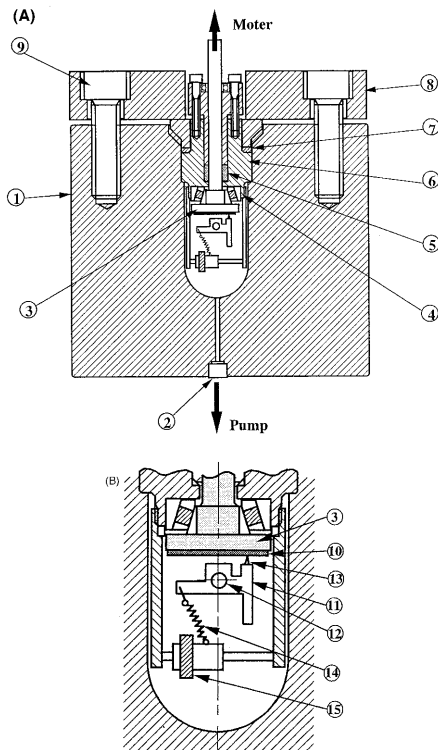

Fig. 3. (A) Schematic of the experimental setup used for the machining of silicon under high external hydrostatic pressures. 1, pressure vessel; 2, pressure intake; 3, turntable; 4, Angular bearing; 5, Bridgman seal; 6, sleeve; 7, Bridgman seal; 8, lid; and 9, bolts to secure the lid. (B) Details of the machining apparatus. 10, work material (specimen); 11, tool holder; 12, fulcrum of the tool holder; 13, diamond stylus; 14, spring; and 15, spring adjuster.

varied in the range of $1.57\text{--}3.14\text{ m s}^{-1}$. Fig. 2 shows the variation of the critical undeformed chip thickness (or critical depth) with the tool rake angle. It can be seen that the critical undeformed chip thickness increases from ~ 70 to 175 nm as the rake angle is decreased from 0 to -40° [14]. Further increase in the negative rake angle up to -80° , results in a decrease in the critical depth to $\sim 40\text{ nm}$. As Komanduri [15] has shown, the use of extremely high negative rake angles result in significant increase in the ratio of the thrust force to the cutting force and reduces the available space for the chip to slide past the tool face. This promotes plane stress conditions and side flow of the material instead of chip formation. Hence, there is no inherent advantage in using rake angle more negative than -40° .

To investigate the effect of external hydrostatic pressure on the ductile machining of silicon, Yoshino et al. [17] built a special machining/scratching stage inside a pressure vessel where external hydrostatic pressure of 400 MPa can be developed. Fig. 3 (A) and (B) are schematics showing details of the machining apparatus built inside the pressure vessel. Kerosene was used as the pressurizing fluid. The pressure vessel was made of steel with a design pressure of 500 MPa . The chamber

was connected to an external high-pressure pump through the pressure intake. The shaft of the turntable is connected to a variable speed motor. Machining experiments were conducted in the range of cutting speeds from 0.8 to 8 mm s^{-1} . The turntable is supported by an angular bearing and leakage around the shaft is prevented using Bridgman seals. Fig. 3 (B) shows details of the machining stage. The silicon specimen is attached to the turntable. A diamond stylus is glued to the tool holder with an epoxy bond and is supported by a fulcrum. The scratches made on the silicon work material by the machining process was examined in a scanning electron microscope.

3. Results and discussion

Fig. 4 (A) and (B) show the machined surface and the corresponding chip generated in machining silicon at an undeformed chip thickness of 868 nm . It can be seen that the machined surface is far from smooth with significant fracture across the entire surface. Fig. 5 (A) and (B) show the machined surface and the corresponding chip generated in machining silicon at an undeformed chip thickness of 58 nm . It can be seen that the machined surface is extremely smooth with no fracture across the entire surface. Also, the chips generated are long and continuous akin to the chips generated when

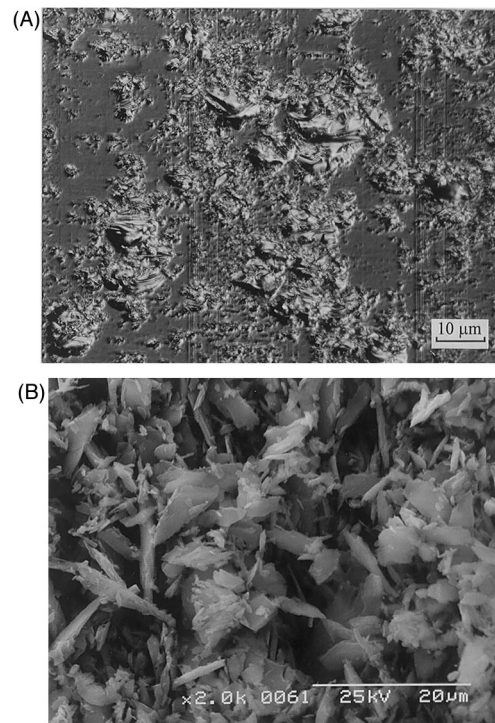

Fig. 4. (A) and (B) Machined surface and the corresponding chips generated in machining silicon at an undeformed chip thickness of 868 nm .

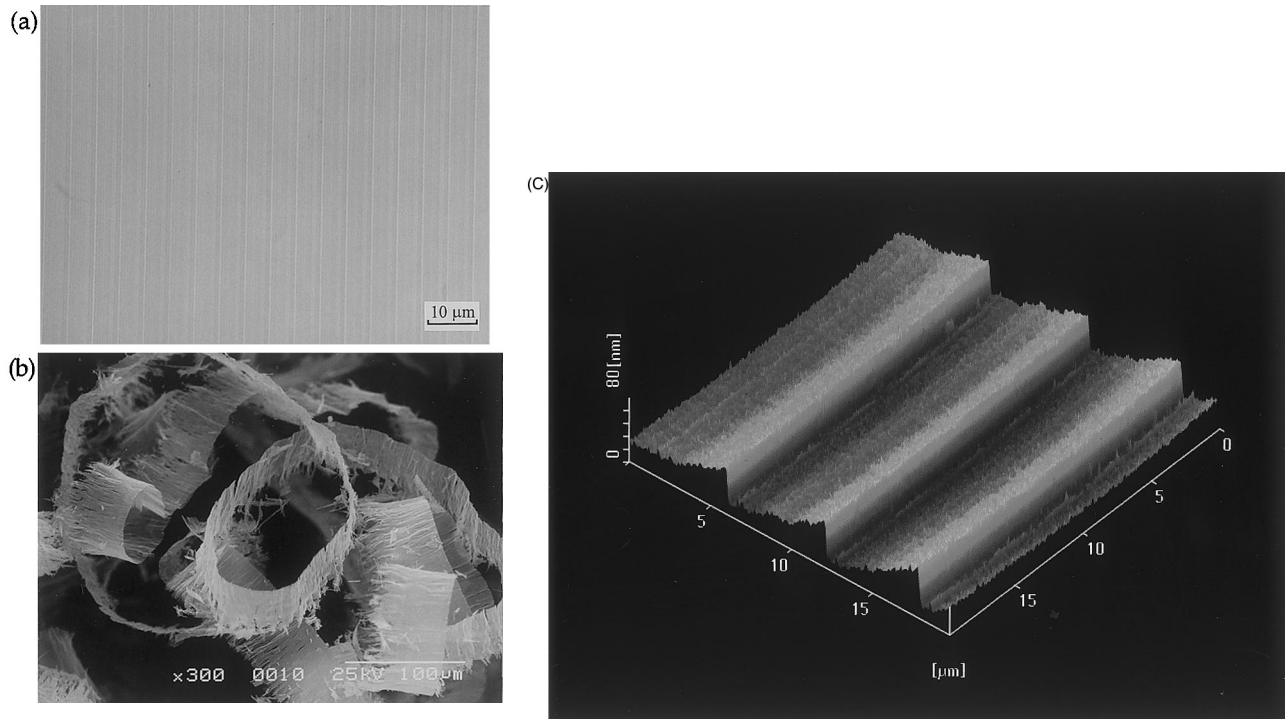

Fig. 5. (A) and (B) Machined surface and the corresponding chips generated in machining silicon at an undeformed chip thickness of 58 nm. (C) Atomic force microscope (AFM) image of the machined surface showing the typical feed marks generated on the machined surface and an extremely smooth surface without any fracture.

machining ductile materials such as aluminum, copper, or, steel. Shibata et al. [16] examined single crystal silicon surfaces by transmission electron microscopy and observed plastic deformation in the machined surface. Fig. 5 (C) shows an atomic force microscope (AFM) image of the machined surface showing the typical feed marks generated in machining and an extremely smooth surface without any fracture.

In order to study the effect of hydrostatic pressure on ductile machining of silicon, machining tests were conducted on a specially built machining stage inside a pressure vessel where external hydrostatic pressure of 400 MPa can be developed through the medium of kerosene. Scratching tests were conducted on silicon using a diamond stylus at 0 and 400 MPa hydrostatic pressure. Fig. 6 (A) and (B) show SEM micrographs of the scratched region showing significant fracture damage at 0 MPa and minimal damage and a smooth groove at 400 MPa hydrostatic pressure, respectively.

4. Concluding remarks

It is shown in this paper that smooth surfaces and ductile machining of silicon yielding continuous chips can be accomplished under the conditions of high hydrostatic pressure, using an extremely rigid, ultraprecision machine tool, a single crystal diamond tool with a large negative rake and a high SCEA and undeformed

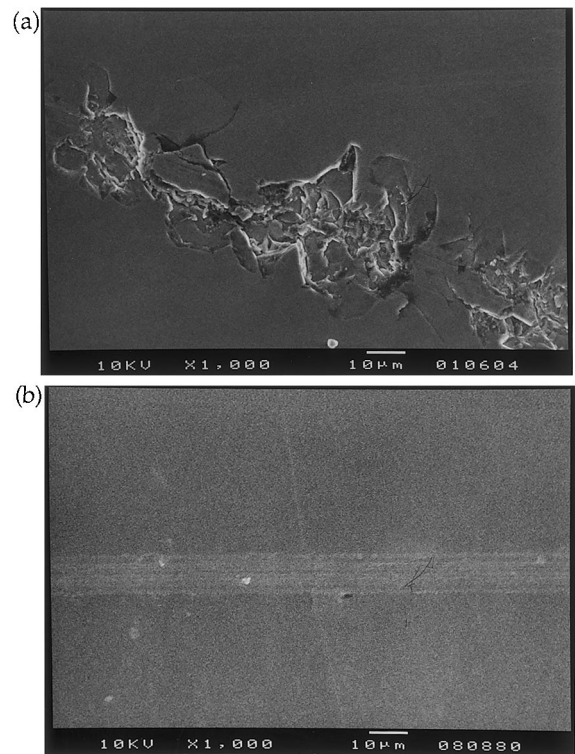

Fig. 6. (A) and (B) SEM micrographs of the scratched region showing significant fracture damage at 0 MPa and minimal damage and a smooth groove at 400 MPa external hydrostatic pressure, respectively.

chip thickness in the nanometric range (~ 50 nm) and a special machining stage inside a high external hydrostatic pressure (~ 400 MPa) apparatus.

Acknowledgements

This work was supported, on the US side, by a grant from the NSF's US-Japan Co-operative Program on High efficiency, damage-free finishing of advanced ceramics and glasses (INT-9603002). One of the authors (R.K.) thanks the National Science Foundation for support of this work. In particular, sincere thanks are extended to Drs B.M. Kramer, L. Martin-Vega, K. Rajurkar, and D. Durham of the Division of Design, Manufacture, and Industrial Innovation (DMII), Dr A. DeAngelis of the International Program, and Dr J. Larsen Basse of the Surface Engineering and Tribology Program at NSF. In addition, the author thanks Dr W. Coblenz of DARPA for his support and encouragement. The author also acknowledges the support from the DOD EPSCoR Program on Finishing of Advanced Ceramics. On the Japanese side, support is acknowledged (K.S and T.K.) from Japan New Energy and Industrial Technology Development Organization (NEDO, RC-11H2003) and the JSPE UltraPrecision Machining Committee (UPM-97-00), as well as the Ministry of Education of Japan (T.S. and M.Y.).

References

- [1] R. Komanduri, *Annal. CIRP* 45 (1996) 509–514.
- [2] R. Komanduri, D.A. Lucca, Y. Tani, *Annal. CIRP* 46 (1997) 545–596.
- [3] W. Johnson, P.B. Meller, *Engineering Plasticity*, D. van Nostrand Co, London, UK, 1973.
- [4] P.W. Bridgman, *Studies in Large Plastic Flow and Fracture with Special Emphasis on the Effects of Hydrostatic Pressure*, McGraw Hill Co, New York, 1953.
- [5] P.W. Bridgman, *J. Appl. Phys.* 18 (1947) 246.
- [6] K.L. Johnson, *J. Mech. Phys. Solids* 18 (1970) 115–126.
- [7] J.B. Pethica, R. Hutchings, W.C. Oliver, *Phil. Mag. A* 48 (4) (1983) 593–606.
- [8] A.P. Gerk, D. Tabor, *Nature* 271 (1978) 732–734.
- [9] A. Kailer, Y.G. Gogotsi, K.G. Nickel, *J. Appl. Phys.* 81 (7) (1997) 3057–3063.
- [10] D.R. Clarke, M.C. Kroll, P.D. Kirchner, R.F. Cook, B.J. Hockey, *Phys. Rev. Lett.* 60 (21) (1988) 2156–2159.
- [11] I.V. Gridneva, V. Milman, V.I. Trefilov, *Phys. Status Solidi A* 14 (1972) 177.
- [12] G.M. Pharr, W.C. Oliver, D.S. Harding, *J. Mater. Res.* 6 (6) (1991) 1129–1130.
- [13] J. Yan, J.K. Syoji, T. Kuriyagawa, H. Suzuki, *Proc. Am. Soc. Precision Eng.* 18 (1998) 128–131.
- [14] J. Yan, J.K. Syoji, T. Kuriyagawa, *Proceedings of the Ninth International Conference on Product Engineering (ICPE) Conference, Osaka, Japan, 1999*, pp. 92–97.
- [15] R. Komanduri, *Int. J. Mach. Tool Des. Res.* 11 (1971) 223–233.
- [16] T. Shibata, K. Ono, E. Kurihara, E. Makino, M. Ikeda, *Appl. Phys. Lett.* 65 (20) (1994) 2553–2557.
- [17] M. Yoshino, T. Aoki, T. Sugisima, T. Shirakashi, *Proceedings of the Autumn Meeting of Japan Society of Precision Engineering, Tokyo, Japan, 1998*, pp. 258.